

Viper DC servomotor drive Manual V2.0.1

Last edited Feb 15 2011

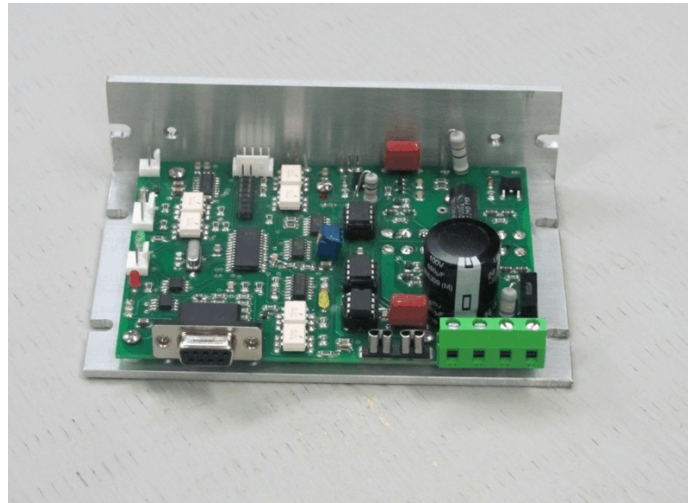

Full featured Industrial quality DC servodrive

Viper 75 25-75 Volt @ 10 amp model

Viper 95 25-95 Volt @ 12 amp model

Viper 100B 25-100 Volt @ 20 amp model

Viper 200B 50-170 Volt @ 20amp model

New Viper 100F 25-100 Volt @ 30 amp model

New Viper 200F 50-170 Volt @ 30 amp model

- 32 bit PID control with 16 bit RISC processor
- 300Khz Step rate on new F series
- Step / Direction Control
- Feed forward command
- Warning output signals excessive motor load (slow down)
- Trip output signals drive has tripped
- Opto isolated power and control sections
- Onboard fuse (protect motor and for safety)
- 4X or 1X quadrature encoder counting
- Separate voltage regulator for encoder power
- 1,2,4,8 step multiplier (or any size)
- Settings are programmable by RS232
- Replaceable Power Mos-Fets and drivers
- Large main capacitor.
- Very efficient cool running drive.
- Stack-able card-type mounting
- Up to 4 motor configurations can be stored
- Jumper selectable motor rotation direction.

DISCLAIMER

Larken Automation assumes no responsibility for any personal injury or damage caused by use of its products.

Only electrically qualified personal should attempt to install the Viper drive.

High voltage can be lethal and proper safety procedures must be followed. Motors and drives should be properly grounded to prevent electrical shock.

Safety glasses should be worn ,since electrical components can explode causing injury or blindness

Copyright Notice

No part of this publication may be reproduced mechanically or electronically in any form without the prior written permission of Larken Automation Inc.

Firmware on the Viper drive is property of Larken Automation and reverse engineering or disassembly of the code is strictly forbidden.

The information in this manual is for informational use only, is subject to change without notice and should not be construed as a commitment by Larken. Larken assumes no responsibility or liability for any errors or inaccuracies that may appear in this document. Viper, Starcam and Starcnc are registered trademarks of Larken Automation Inc.

© 2006, [Larken Automation Inc.](#)

Tech support

Contact

Larken Automation Inc.

5350 Canotek Unit 13

Ottawa, Ontario

Canada, K1J 9E1

Ph: (613) 746-5685

Fax: (613) 746-6451

E-Mail: Larken@storm.ca

Website: www.Viperservo.com

Website: www.LarkenCNC.com

DC Servo Motor Basics

The DC servo motor has an optical encoder that provides feedback to the controller. This typically can have from 100-5000 counts per turn.

The most popular type of encoder is the optical encoder, which consists of a rotating disk, a light source, and a 2 photodetectors (light sensor). The disk, which is mounted on the rotating shaft, has many slots in it. As the disk rotates, these slots interrupt the light emitted onto the photodetector, generating a digital or pulse train.

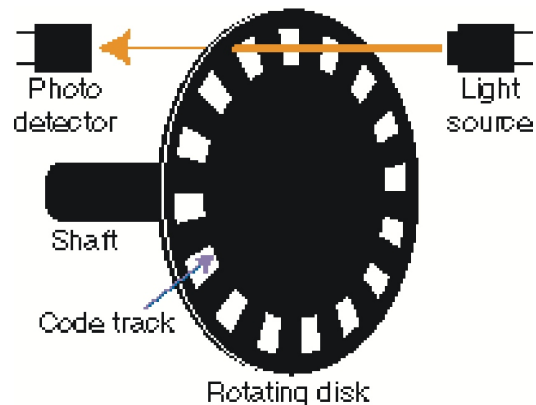

The encoder has 2 square wave outputs. They are staggered at 90 deg. This way one is leading the other when turning CW and then trailing the other when turning CCW.

These are Channel A and B. The controller can tell which way the motor is turning by the A-B sequence. There may be an optional Index output also. (The index is not used by the Viper)

Encoder Outputs

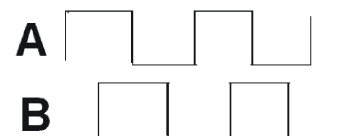

A **differential encoder** has 2 outputs for A channel and 2 outputs for B channel. The second output is an inverted version of the original and is designed to drive a twisted pair cable to cancel noise. Differential encoders are recommended for motors with cables longer than 4-6 feet.

Encoder Line count is the number of lines per turn. With-in the viper drive the line count is decoded 4 times finer (quadrature), so with a 1000 line encoder, the viper drive sees 4000 counts/turn. This is not to increase machine resolution, but to give the drive more counts to reduce error.

The **Step Multiplier** setting in the viper sets the ratio of incoming Step/direction pulses from the control software to the 4X encoder counts.

So with a 1000 line encoder and a step-multiplier of 4 you would have 1000 steps/turn. With a step multiplier of 8 you would have 500 steps/turn.

With a step multiplier of 1 you would have 4000 steps/turn, but don't be fooled thinking your machine will be more accurate. A servo system always runs with a error of at least a few encoder counts. Also it would require a very high input step rate to make the motor spin fast.

We recommend a 1000 line differential encoder for most applications. Encoders with less than 400 counts/turn should be avoided. The viper can handle up to 625Khz encoder frequency (assuming good cableing)

A good source for encoders is US-Digital.com

The **DC servo motor** has a Permanent Magnet outside (stator) and a wire wound armature. Carbon brushes connect the electrical power to the rotating armature. They can either have 2 or 4 brushes. A motor with 4 brushes gives a smoother motion.

The motor also acts as a generator while spinning and under deceleration can force power back into the drive . A fast decelerating motor or a load pushing the motor can increase the power-supply voltage. Viper drives have at least a 25% voltage headroom and can handle moderate over voltage.

The Viper drive uses a Mos-Fet or an IGBT bridge to drive the servo motor.
The signal is Pulse Width Modulation or PWM with a frequency of 20,000 HZ

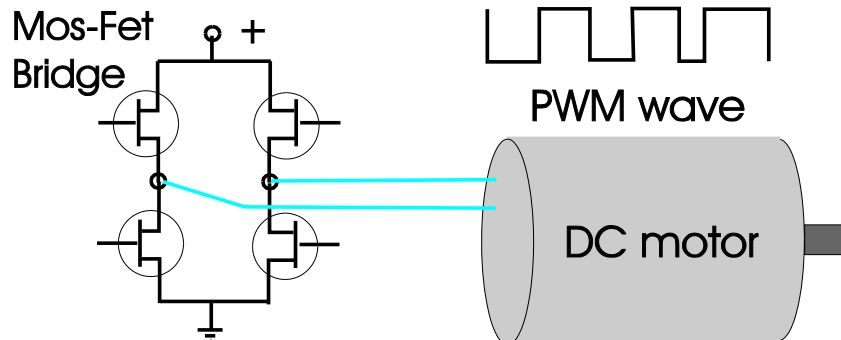

Viper 75 /95 Drive Connections

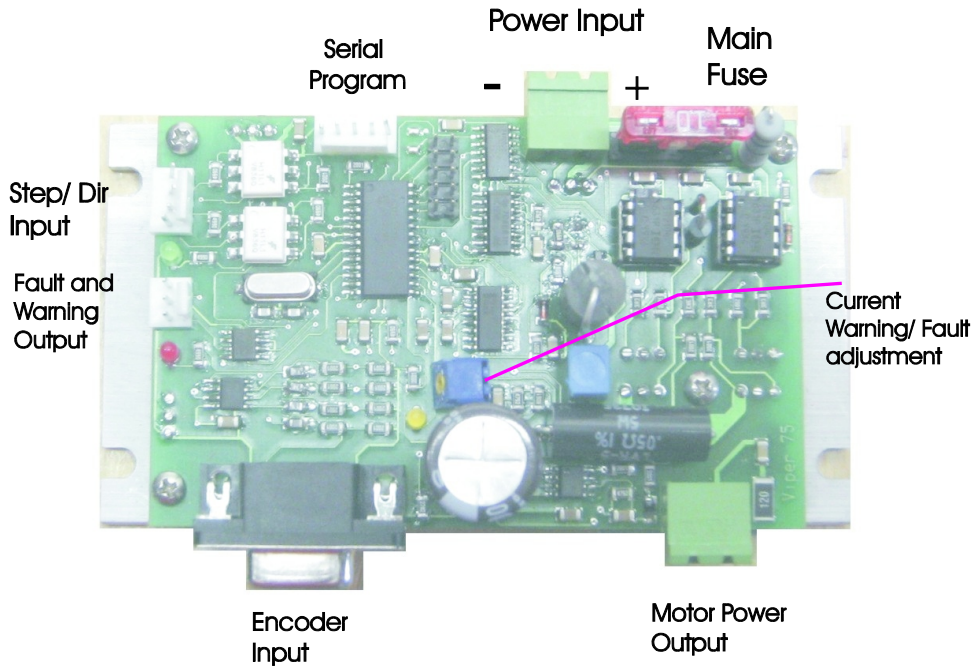

Viper 100/200 Drive Connectors

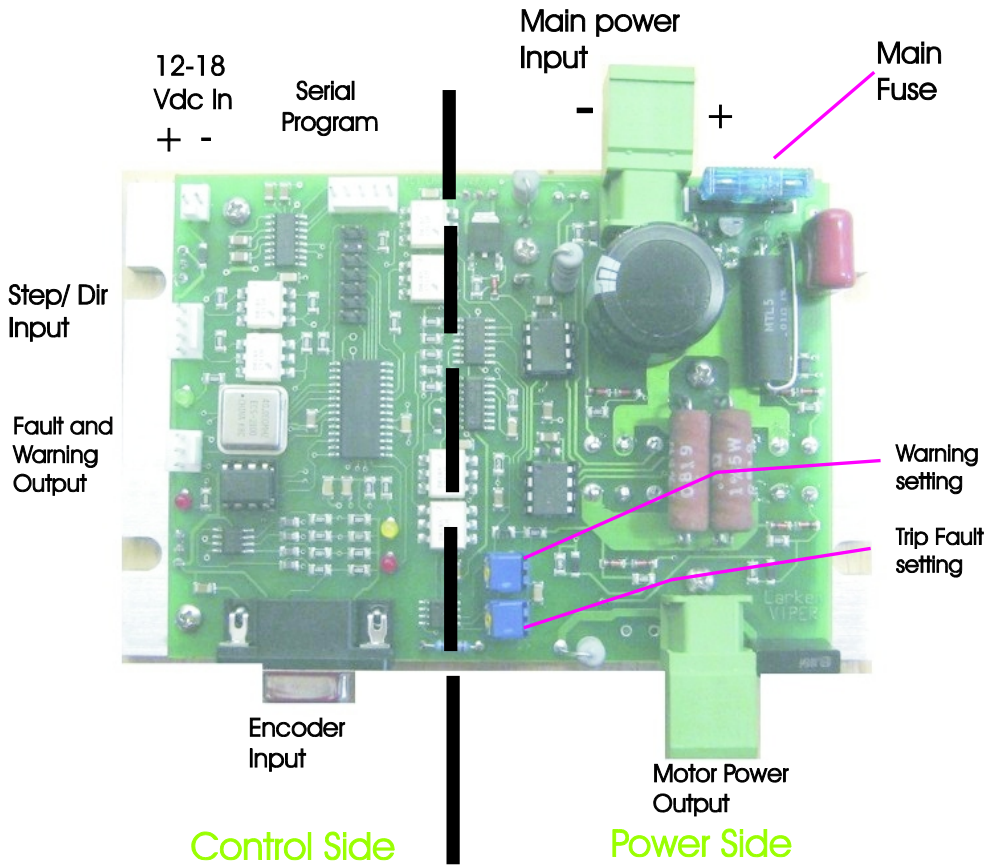

Viper 100F /200F Drive Connectors

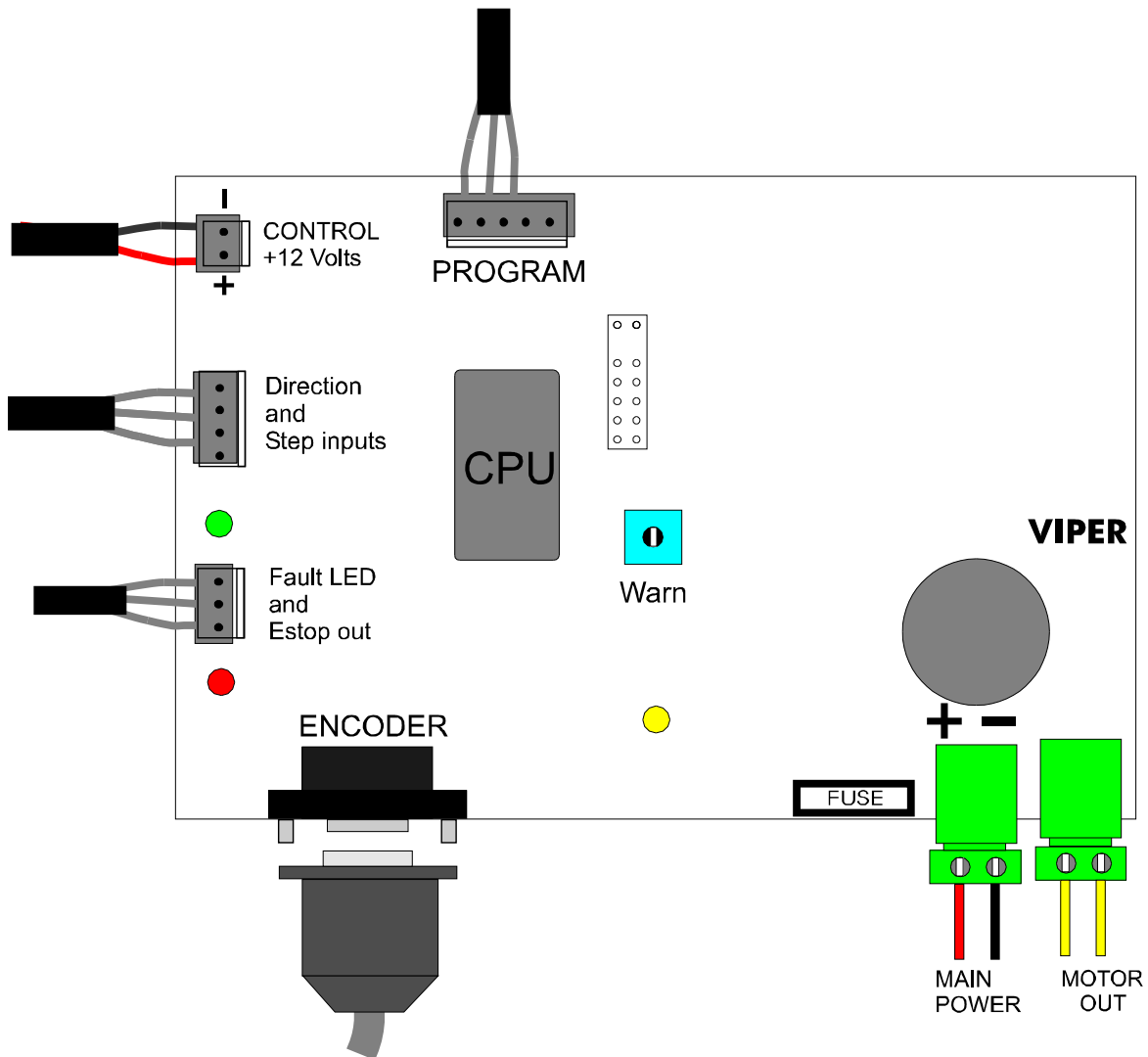

Differences between Viper 100/200 A and Viper 100/200F (after 2011)

- The older Viper drives couldn't read actual Current. They used a set value set by a trim pot and could only see if the motor current was above or below that. The F series Viper 95 and 100/200 can read current and the max motor current is now a software setting.

- The F series drives can run up to 300Khz step input vs 125 khz for the older drives.

Differences Viper 100/200 A vs Viper 100/200F continued

- The baudrate for the serial connection is now 38400 baud vs the previous drive which were 9600 baud.
- Low voltage detection is a new feature that detects whether main power on the V100F /200F is turned off and disables the drive until it comes back on. It then soft starts after a 2 seconds. Note position is cleared so the motor doesn't jump.
- The viper 95 low voltage detection disables and locks drive when voltage dips. This brownout detection protects the drive since the CPU can be unpredictable during low voltage situations.
- On the V100F /200F power and motor connectors are moved to one side for easier mounting in cabinets.

Selecting a Powersupply Voltage

Motors typically specify a maximum DC voltage and maximum RPM. EG: and MCG ID34002 servo motor has a max DC voltage of 90 volts and runs 5000 rpm at 90 volts. These are maximum ratings, however you can set the powersupply lower than this to run the motor slower.

In a motor, the **voltage** determines the **RPM** and the **current** determines the **Torque**. When the motor is running with no load, the current is small. As the load increases the motor draws more current from the power supply.

Current in motors are rated by **Continuous stall current**. This is the maximum current the motor can take continuously without overheating. You probably won't be running the motor this hard all the time, so the power supply can be rated at a lower current, maybe 60% of this value.

Most power-supplys can output 1.5 times there rated power for a short time, and since the average power used by the servo system is usually low, you can usually use a power supply with a lower VA rating than total calculated power.

The **Fuse** in the Viper drive should be the value of the continuous stall current or slightly above to **protect the motor**.

The other current-rating of the motor is the pulsed peak current. This is the current that motor damage can occur if exceeded.

The Viper drives can output peak currents at 200% of their rated current for less than 1 second.

Setting a Safe Maximum RPM

You must decide what is the maximum RPM that you want the motor to run on your machine, incase of a possible drive failure. (This may put full power supply voltage to the motor and case a dangerous situation)

As a rule, set your power-supply voltage to only about 10-20% higher than what you would need for your maximum rapid feed rate.

Running the motors at a lower voltage also reduces heat in the motor and drive and increases motor and brush life.

Viper 100/200 Power supply recommended layout

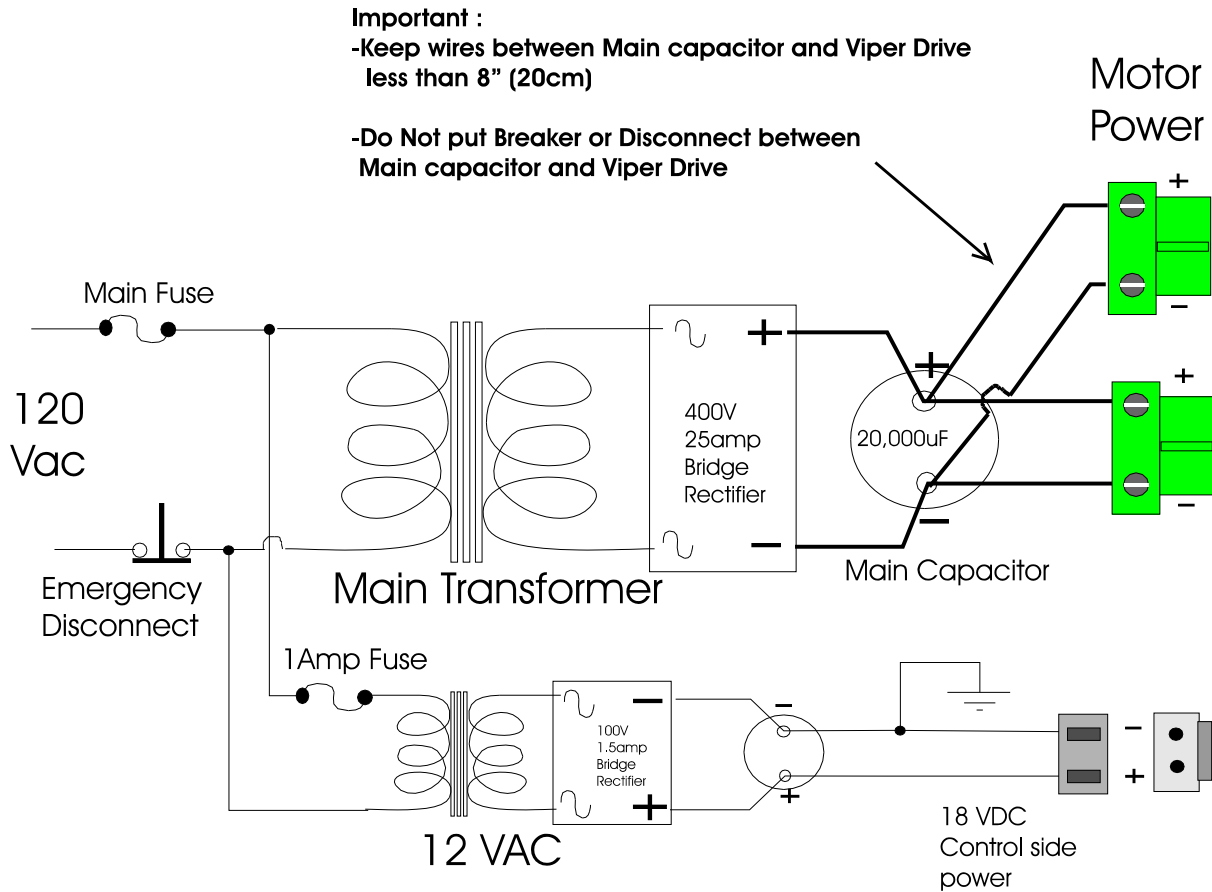

The viper 200 uses Isolated Power and small signal sections to eliminate ground problems associated with high power controls. This increases reliability and reduces ground and noise problems.

- The main transformer voltage is to match motor voltage requirements.
 ($DC\ volts = AC\ voltage \times 1.414$)

- Keep the main DC power wires short, typically 8" (20cm) or less. This is necessary because the drive is switching a 20 Khz power signal to the motor. This frequency is present on the incoming power wires and the longer they are the more inductance there is. This can cause voltage spikes to exceed ratings of the mosfets and capacitors reducing component life.

Viper 100/200 Power supply recommended layout (continued)

- **Do not put a breaker or disconnect between main capacitor and drive.** This can cause a extremely high in-rush current to the drive when the contact is closed ! This is because the energized main capacitor will discharge into the unpowered drive and can damage connectors and PCB traces.

Put your disconnects before the transformer to give a softer powerup. Also the disconnect should shut down **both** 12volt and motor power together, to prevent the motor from jumping back to position if the 12 volt encoder and control power was kept active.

-The 12volt can be disconnected while leaving the main power on however. This can be used to reset the drive.

- The 12volt may be powered from the main transformer as a 2nd winding, but must be isolated .

- The high power side of the viper is isolated from ground and small signal side. It is best to keep this side isolated

- The heatsink is isolated from the viper circuit.

- The '*side mount*' Viper drive is designed to be mounted vertically with its encoder and motor connectors through the bach of the cabinet. The mounting screws are 8-32
The size of the Fuse should be slightly above the motors continuous current rating.

The fuse is to protect the motor from burnout !

Note: The small signal side will be grounded the to chassis ground by encoder connector (9 pin D-type) when mounted to a case.

Warning Voltages over 80 volts can be lethal. Be sure to ground the motor frame when testing and have viper drive mounted in grounded chassis when testing.

Viper 75/95 Power supply recommended layout

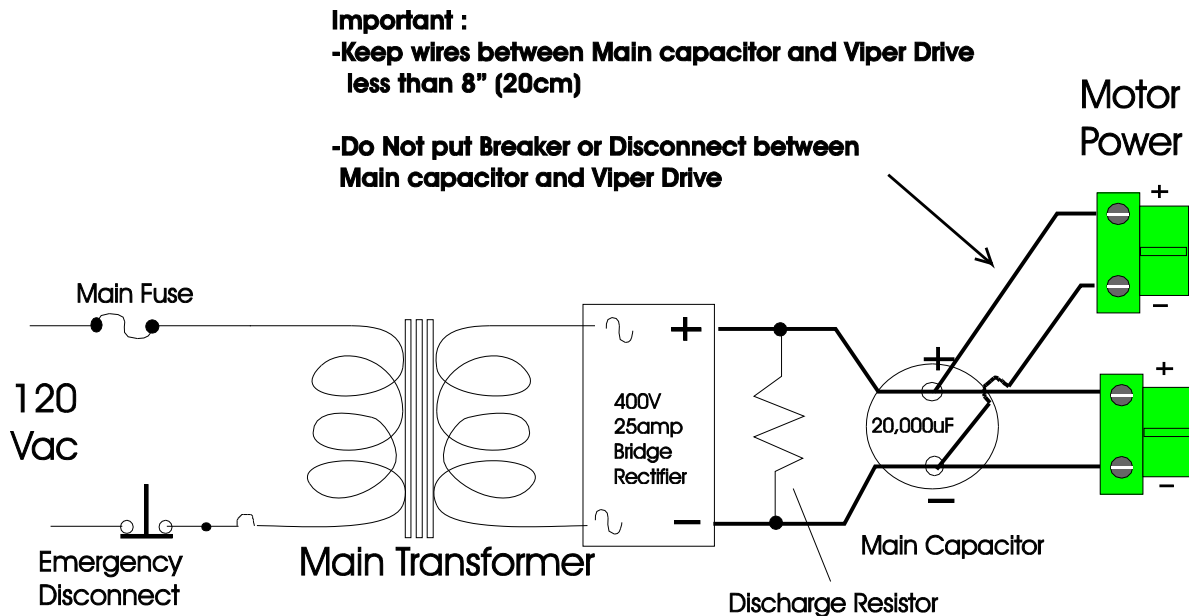

The viper 75 uses a single supply voltage. The drive uses a voltage stepdown regulator to get its +5 voltage for cpu and encoder. This can generate a lot of heat so the drive should be well heat sinked.

- The main transformer voltage is to match motor voltage requirements.
($DC\ volts = AC\ voltage \times 1.414$)
- Keep the main DC power wires short, typically 8" (20cm) or less. This is necessary because the drive is switching a 20 KHz power signal to the motor. This frequency is present on the incoming power wires and the longer they are the more inductance there is. This can cause voltage spikes to exceed ratings of the mosfets and capacitors reducing component life.

The Viper 75 CPU will stay active until its voltage goes below 3.5 volts. This means that when you turn off the power supply and turn it back on before the voltage has decayed below 2-3 volts the viper may not have reset.

The Discharge Resistor is required to drain the power supply faster to allow the Viper 75 to get below its 2 volt reset voltage.

Also the Viper 75 has a **Brown-out Voltage Fault** to protect the mosfets incase the power supply goes below 15 volts. This causes the error light to go on steady.

Note: The viper 75 will be grounded the to chassis ground by encoder connector (9 pin D-type) when mounted to a case. This is recommended to reduce noise in the encoder cables. The negative power supply input is common to the encoder connector case as well.

Viper Interface connections

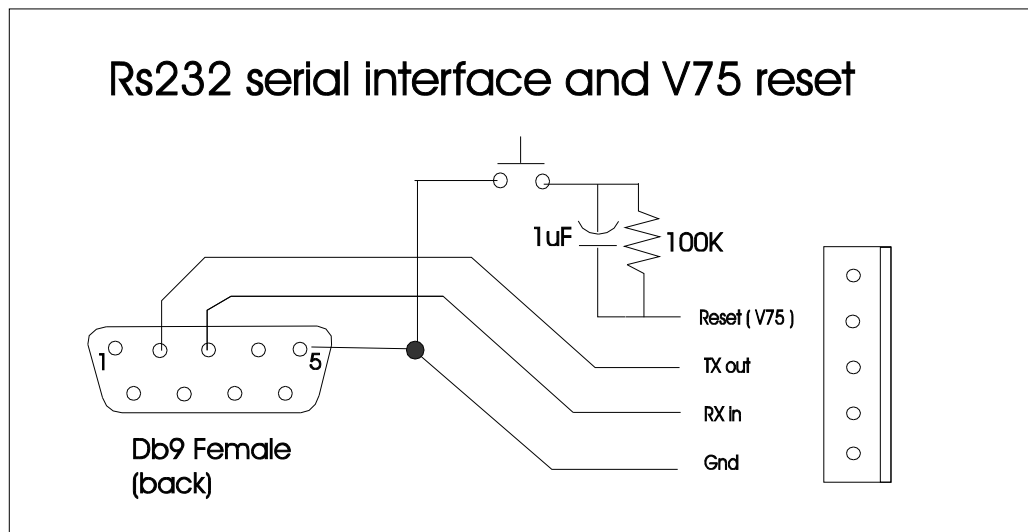
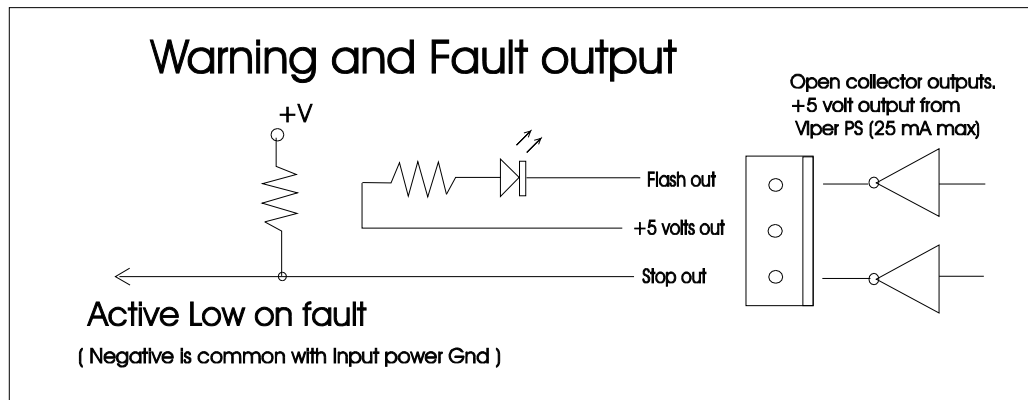
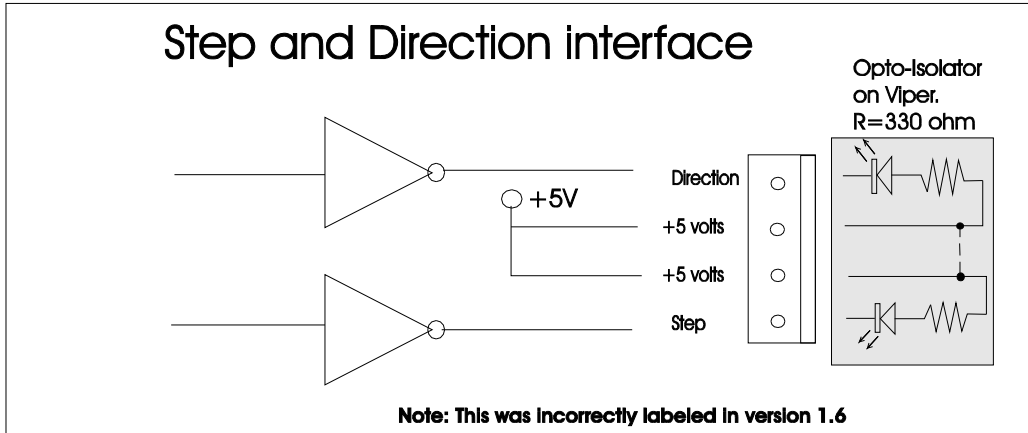

The RS232 programming cable is available from Larken Automation

Fault output for multiple Drives

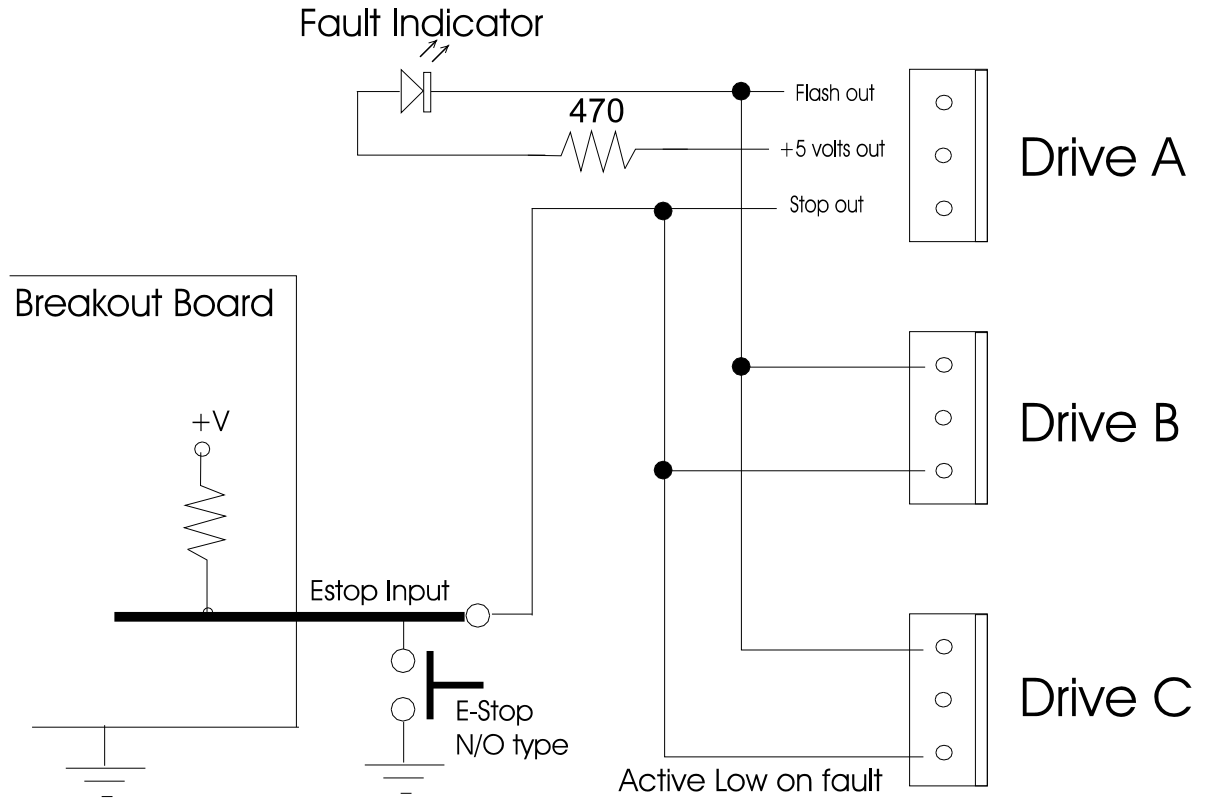

BOB should share common Negative or Gnd with Viper



Viper can be grounded by mounting encoder connector in a chassis or by grounding the NEG wire of 12V power

Motor Encoder and Power connections

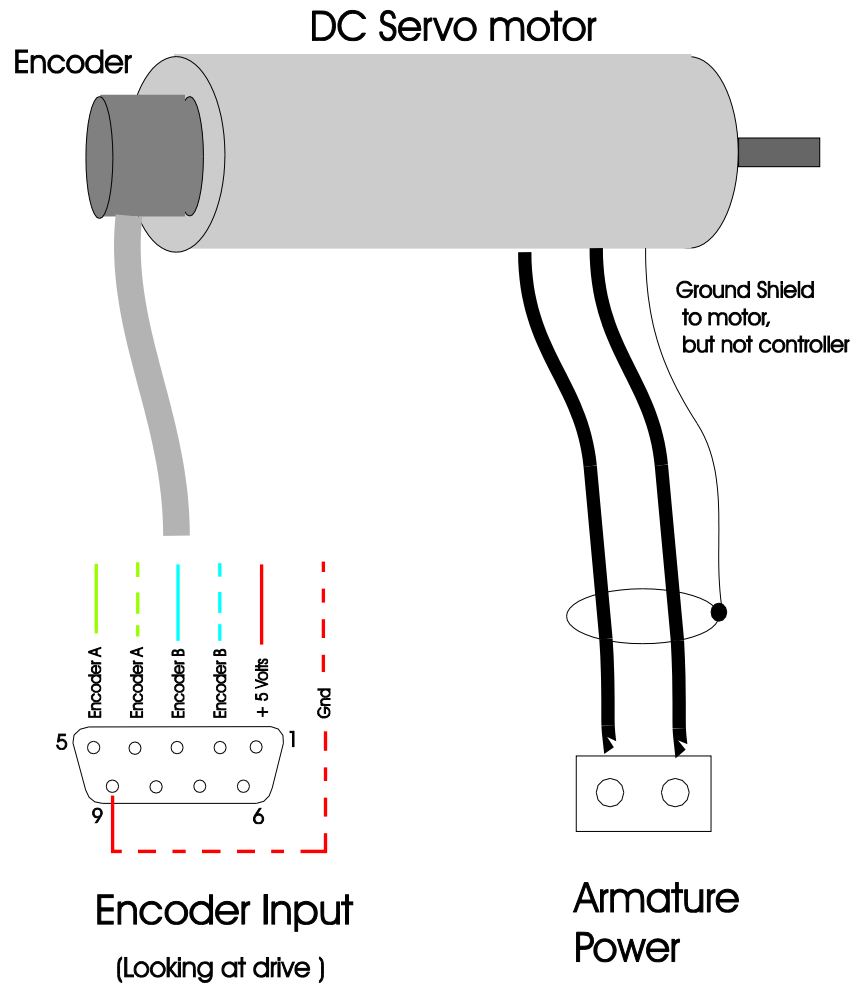

- Use twisted pair network cable for encoder cable. Stranded wire (not solid)

Note : Diagram shown for a differential encoder. For a single ended encoder, use just one connection per channel. Use (stranded) twisted pair cable for encoder wire. Use shielded wire if available. Connect the shield on *one end only* to avoid current flowing in shield.

Encoder Current

Note: Encoder current is limited to **75ma on the Viper 75 / 95** due to the internal voltage regulator dropping the Main voltage down to 5 volts

Viper 100 / 200 maximum encoder current is 250 ma

Viper 75/ 95 maximum encoder current is 75 ma

Encoder connections

Pin 1	+5 volts out for encoder power
Pin 2	Channel B input (inverted)
Pin 3	Channel B input
Pin 4	Channel A input (inverted)
Pin 5	Channel A input
Pin 6	N/C
Pin 7	N/C
Pin 8	N/C
Pin 9	Gnd

Single Ended encoders

When connecting a single ended encoder, the unused input should be pulled to ground with a 2K ohm resistor (2000 ohm 1/4 watt).

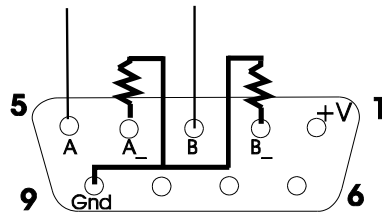

Single Ended Connections

Terminating long cables

A differential encoder is recommended for any cable longer than 6 feet (2 meters). For very long cables it is sometimes necessary to put a terminator resistor across the differential pairs. The resistor value is usually 150 ohms (1/4 watt), A 0.05uF capacitor may be put in series with the resistor to reduce power consumption..

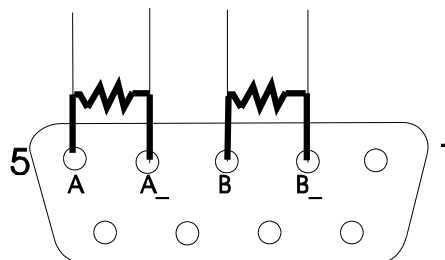

Terminator resistors

Understanding PID control

PID stands for *Proportional-Integral-Derivative*. These are the 3 adjustable factors that make the controller able to keep the motor stable in the servo loop. All factors are adjustable in magnitude by the user. A servo works by constantly correcting the position error. The error is the difference between the encoder position and the step/dir counter.

The **Proportional term** (KP) directly outputs voltage to the motor in opposite proportion to the error. By its self though, the motor will just bounce back and forth in oscillation as this is factor increased.

The **Derivative term** (KD) keeps the loop stable by comparing the latest error amount to the last error amount. If it sees the error getting worse (over the last 2 loops), then it increases the power in the opposite direction to correct. If it sees the error getting less, then it reduces the correcting power to the motor.

The **Integral term** (KI) is a correcting factor that helps correct a positioning error by increasing the correction higher as time goes by. EG if a load was hard to move one way and caused a steady error to the left, the Integral would push harder and harder to the right on each loop of the servo timing, building up as time goes by. As the load corrected, the servo would reduce pushing to the right.

Servo Loop

The controller runs a software loop which reads the encoder and calculates a new output power and polarity to the motors thousands of times a second.

LOOP

Read encoder (motor position)

Read commanded position (from step and direction input)

Subtract the two to get the error.

Calculate $KP * \text{error}$ = proportional result

Calculate $KI * \text{Integral error sum}$ = Integral result

Calculate $KD * \text{error}(T) - \text{error}(T-1)$ = Derivative result

Add all 3 results to create the output correction value

Convert to a PWM duty cycle and output to motor

JUMP to LOOP START

The loops per second is an other programable setting in the Viper drive. This has a big effect in matching the mechanical reaction time of the motor. Generally the heavier the motor armature, the slower the loop timing needed.

Note: a motor can only respond so fast to changes in position correction.

Some drive manufacturers claim very high loop times of millions of loops per second. A typical motor can only change its acceleration/ deceleration velocity at a rate of a few hundreds of a second. Also if the PWM frequency is 20,000 cycles per second. The loop time has to be slower than the PWM.

Programming the Viper Drive

The Viper is programmed by connecting to a PC using the serial RS232 port. A cable can be made as described above. More info and the viper command set is at the end of this document.

Run the windows **Hyper Terminal** program from the Accessories group. Create a New session using Comm1, **9600 baud**, 8,1,N.

(Note: on software version 3.0 or greater Baudrate is **38400 baud**. This is on drives that flash errors as a count (*not by speed*)) All new Fseries drives run at 38400 baud (after Jan 2011)

All commands are entered in lowercase and followed by a 'carriage return' <cr>.

Note: The viper command set is at the end of this document.

When you apply power to the viper, the letters LKR should appear on the PC screen. Pressing <enter> should return a : prompt

Initial programming and testing can be done with the drive just connected to **Control power** as shown below (use main power on V75/V95). The serial cable needs to be connected for tuning using a windows PC running Hyperterm.

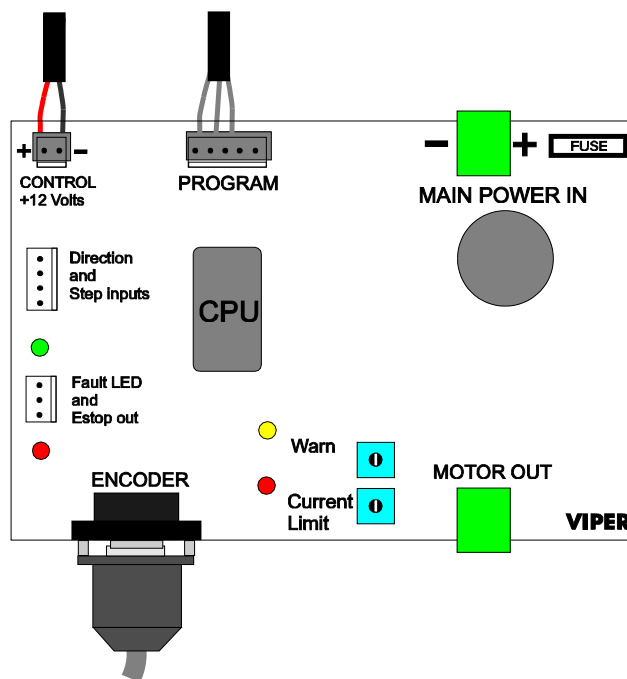

Use this setup to test the encoder using the M command. When power is first applied the m000 s0000 will display. (m=Motor position, s=Step position) .

Turning the motor one way should increase the encoder counter and the other way should decrease it into negative values. Note: this register is displayed in 16 bit Hex, so negative starts from FFFF and gets smaller.

Also you can set the range command (r) to the number of motor counts of error before the drive faults and flashes the LED. You can also set up a number of other parameters without having the motor power connected.

Get familiar with the drive before connecting the main motor power.

Tuning the PID loop

Note: Be sure to have the motor mounted or clamp the motor to a table before tuning! The motor can react very violently and cause damage or personal injury.

Note: Remove the bank jumpers (Bank 0) so the drive runs in **current limited mode** when checking the wiring on a motor for the first time.

Start with $KP = 100$, $KI = 0$, $KD = 200$ and $Loop = 4$

1) Adjust the Loop Time parameter one unit at a time either way until the motor reduces its oscillation and disturbed response becomes most dampened. (The range of the loop parameter is 1-8)

Disturb the motor with an abrupt jog or bumping a pulley

After this is set you shouldn't need to change this parameter.

The **Loop parameter** matches the response to the mass of the motor and load.

EG: Very small motors may use a L setting of 1-2 ,

-Size 23 motors may use 2,3 or 4.

-Size 34 motors may use 3,4 or 5.

-Size 42 motors may use 4 -8 etc.

The length (mass) of the lead screw of size of a pulley will effect the L setting as well.

2) Increase KP, 50 points at a time until the motor gets stiffer.

3) Keep increasing KP until the motor starts to oscillate when disturbed (bump the shaft or accelerate back and forth).

4) Then increase KD until the motor is stable. KD usually ends up about 2 times KP.

5) The KI term is usually a very small value (2-20) since it adds to its self rapidly. The KI should be set to zero until KP and KD have been adjusted.

6) Save the parameters by using the 's' command. (Saving is disabled in bank0, Parameters in banks 1,2 and 3 can be saved)

Note: The power supply voltage also plays a part to the tuning. For any given motor, KP and KD will need to be less when the power-supply voltage is high, compared to if the voltage was lower. This is because a certain gain produces a duty cycle, and the actual voltage to the motor is the power-supply voltage * duty cycle.

Tuning Summary

- **KP** Sets the stiffness of the motor.
- **KD** settles the oscillation and overshoot.
- The **Loop time** needs to be matched to the motor and load early in the tuning when the KP and KD are at lower values, but can be re-adjusted at final tuning.
- **KI** can be added at the end to improve low-speed holding error.
- The L setting should be set early on in tuning and matches the motors mass.

Other settings include Range, Trip, Feed-Forward

Encoder Limit settings

There are 2 settings to signal that the following error is out of range.

The **Range** setting can be set to output a error warning to stop the cnc controller if the following error is to high. This will hold down the Estop signal, but **not disable** the Viper drive.

The **Trip** setting **will disable** the drive if exceeded, and hold down the Estop to the cnc controller.

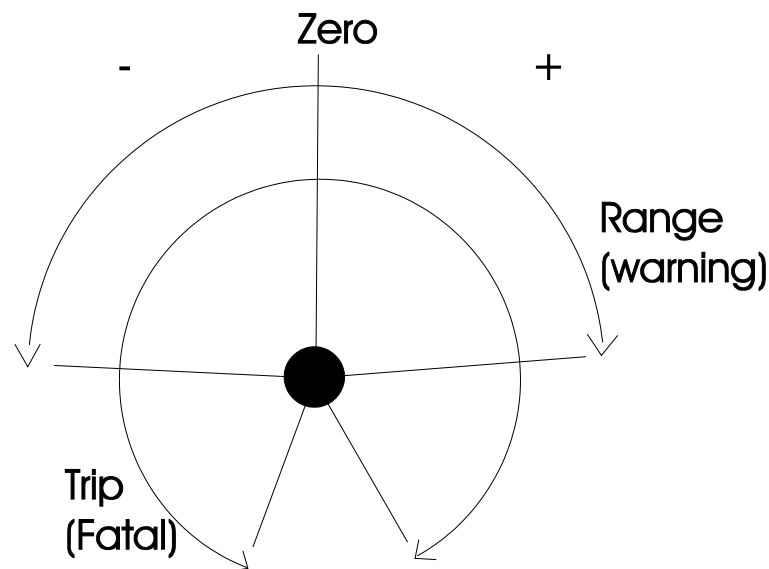

Both Trip and Range are in quadrature counts (lines x 4) so to set the Trip command to 3/4 of a turn of a 500 line encoder, the setting would be 1500

This setting is designed to **protect** the drive and motor when an extreme out of range is detected. The max setting allowed for the Trip command is 4000.

Feed_Forward parameter

With a Stepservo drive, the faster the input step rate, the larger the following error. This is because the motor is 'pulled' along by the incoming pulse train.

The Feedforward parameter can reduce high-speed following error by adding a push that is proportional to the speed of the incoming step pulses.

Leave the 'f' command to zero until you get the drive tuned with the PID and L parameters.

While running the motor, read the error with the 'e' command. Increase the 'f' command until the error becomes close to zero. Start off slow and increase the speed while increasing the 'f' command.

Too much Feedforward will create a leading following error.

Typically the F parameter may end up being close to the P parameter.

Using Banks for storing multiple configurations

The Viper drive allows you to setup 3 different preset configurations. This allows the drive to be Jumper selectable in the field for your most common motors.

(See jumper settings at the end of this manual)

When you power-up the drive the current bank selected will be the one you are tuning in this session. When done tuning that bank, Save the parameters to the EEprom with the 's' command and then you can turn the drive off.

Testing a new motor for the first time (Bank 0)

When Bank 0 (no jumpers) is selected the Viper will limit the power to the motor by 60% to protect the drive from over-current when setting up a new motor.

It's a good idea to put a 5-10 ohm 10 watt resistor in series with the motor power (when testing only) since if an encoder is not wired correctly the motor can violently oscillate possibly causing drive damage by excessive current. Remove the resistor after the wiring is confirmed correct.

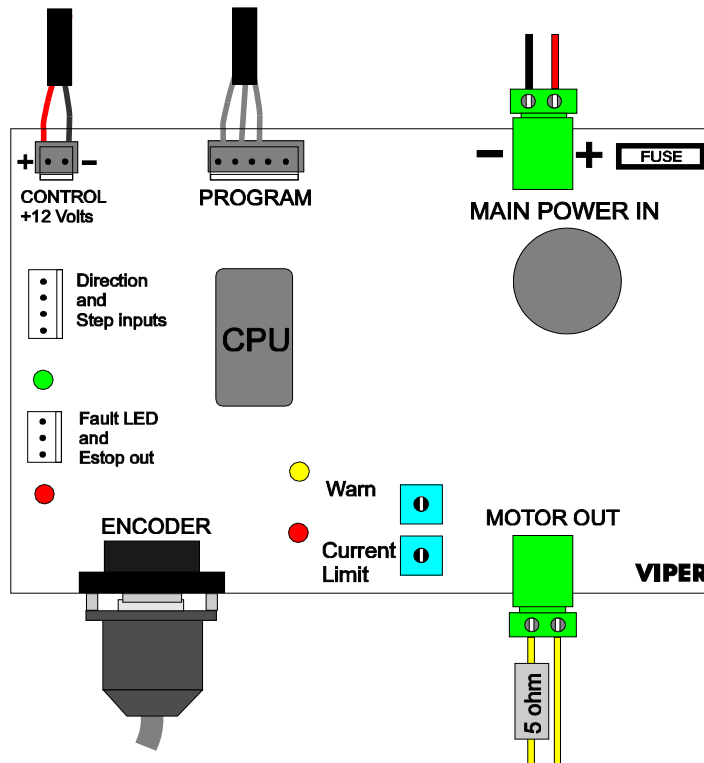

You can also set the **PWM Clip limit** command 'c' to 200 to limit the maximum power to the motor. Its range is 100-450 (450 = 90% PWM).

You can use Bank 0 to test and program parameters for the motor, then write them down and enter them in an other bank.

Only Bank 0 is current limited. The default KP, KI and KD are set to low values in this bank for testing motors.

Note: The motor should 'hold' when power is applied if correctly wired.

If the Motor runs away when turned on

If when setting up the motor for the 1st time and it runs on when power is applied, Reverse the power connections to the motor. (Or reverse encoder channels A-B)

Note: The limit resistor needs to only be there for setup and should be removed before final tuning . Use the Clip command to limit power to the motor while tuning.

Setting Motor Current

(on New Viper F series with advanced current control)

The Viper can control the current to the motor to protect it from burnout. Motors are rated with 2 ratings **Continuous Stall** current and **Peak Current**. The peak current is the absolute maximum momentary amount of current the motor can take for before damage to brushes or windings occur.

The rating that's important is the Continuous stall current. This is the maximum continuous current the motor can take before windings overheat and destroy themselves. The drive needs to know this rating to be able to protect the motor against heavy overloads. If the drive sees this current exceeded for more than 2-3 seconds, it will shut down the drive and cause an overcurrent error (error 6)

When the drive sees very high current, it automatically reduces the current to the continuous rating. If this current stays for 2-3 seconds, the drive shuts down. It allows peak currents up to 45 amps under acceleration/ decel but reduces it quickly to the safe limit and holds it there.

To set the current first you need to know the **Continuous Current rating** (stall) of the motor. The drive can't accept the actual number, but you enter a lookup value from the table below. EG to set the Viper 200 to 12 amps, enter the command a61
Use the table below to get the correct value to enter in the Viper and enter it using the 'a' command. (This value is used by the ADC converter on the PIC chip.).

Viper 100/200F Amps	'a' value for V200		Viper 95F Amps	'a' value for V95
5	25		2	66
6	30		3	81
7	35		4	98
8	41		5	107
9	46		6	117
10	51		7	127
12	61		8	136
14	71		9	146
16	81		10	158
18	91		11	168
20	102		12	174
22	112			
24	122			
26	132			
28	142			
30	153			

(To reset the drive ,disconnect the 12volt to the control side to Reset power to the drive to reset the trip fault).

Adjusting the Current Warning pot

The adjustable trim pot on the drive allows you to set a 'Warning current' level that is less than the max motor current . This can be set to indicate the machine is under excessive load cause by a dull cutter, or jamming condition etc.

The warn doesn't trip the drive, but flashes the Fault light (3 flashes) and holds down the 'Stop' output if the current stays high for more than 2 seconds. When the load reduces, the error goes away.

The Viper has 2 output signals. One is to power a flashing LED on the front panel of the controller, and the other should be connected to your Estop signal to stop the motion commands. These are open collector outputs and can be parallel connected to multiple Viper drives.

Note : Its important to connect the error outputs back to the breakout board to stop the control software.

Viper Error Indicator LED (F series)

When an error is flashed, the Viper will hold down the Estop signal until the error is removed. You can add a Fault override switch (normally closed) in this estop line to allow the operator to jog the machine while holding the switch to recover from a warning error.

It will flash the RED led a count indicating the error number

LED error count (Version 3.0 + firmware)

- 2 Encoder Range warning (r command)
- 3 Current warn (Pot adjustment)
- 4 Under voltage on main power
- 5 Encoder Trip (t setting)
- 6 Current Trip (exceeded motor current)
- 7 Encoder fail (no pulses)
- 8 Short circuit protection

Errors can be reset by turning off the power (12volts on V200) or using the 'x' command through the terminal.

The Under voltage error will stop when the viper 200 sees the power come back on. The drive will soft start after a few seconds. But the Error value '64' is kept stored in the error register in the drive. This allows you to poll the drive to see if an under voltage happened while the drive was running

In parameter display 2 (seen by pressing 2<cr> in terminal) the Er line has 2 parameters

The first parameter is the error register which holds a code the same as the flash count. The second number is the *Bit Coded Live Error Flags*. This is a binary number showing current read errors. This can show more than one error. EG Encoder trip and under volt.

- Bit 0 Trip current
- Bit 1 warn current
- Bit 2 Encoder range
- Bit 3 Encoder Trip
- Bit 4 Under voltage
- Bit 5 Encoder fail
- Bit 6 ----
- Bit 7 Short circuit fault

EG: Er 04,11 04= Under voltage 11=current trip and undervolts

Adjusting Current limit and Current warning

(For older Viper A & B series with trim pots)

There are two trim pots on the Viper. The one closest to the edge of the board is the Current Trip setting, and the other is the Current Warning setting.

Turning these pots (potentiometers) CW increases the amount of current allowed to the motor, and turning them CCW makes them trip at a lower current.

NOTE : use a plastic or non metallic screw driver to adjust these pots, to prevent shorts or electrical shock if the screwdriver touches the PCB board.

Adjusting the Current Limit and Trip

To start adjust the both pots at about midpoint. With the motor holding, apply a twisting to the shaft to simulate an excessive load of the amount that you want to trip the drive.

Note: Be careful not to cause excessive high current and damage motor or drive.

While holding the motor in this position, adjust the trip pot CCW until the red LED lights. The motor shaft may cycle slightly as the CPU reduces and holds the PWM cycle indicating current limiting.

Holding the red light on for 2 seconds will make the drive cut the power to the motor and flash the Fault light rapidly. This is a fault trip condition.

(To reset the drive ,disconnect the 12volt to the control side to Reset power to the drive to reset the trip fault).

Adjusting the Current Warning pot

Do the same to adjust the Warning limit pot with less of a load on the motor. The yellow LED is used to set this current. Use a small load to activate the Warn setting.

The warn doesn't trip the drive, but flashes slowly the Fault light and holds down the 'Stop' output if the current stays high for more than 2 seconds. When the load reduces, the error goes away. Set the Yellow LED to come on at a lower load than the red.

This can be set to indicate the machine is under excessive load cause by a dull cutter, or jamming condition etc.

The Software error range setting causes the Fault light to flash very slowly and holds down the 'Stop' output as well if the motor goes out of range for more that 2 seconds. When the motor error is less than the range setting the error goes away.

The Viper has 2 output signals. One is to power a flashing LED on the front panel of the controller, and the other should be connected to your Estop signal to stop the motion commands. These are open collector outputs and can be parallel connected to multiple Viper drives.

When an error is flashed, the Viper will hold down the Estop signal until the error is removed. You can add a Fault override switch (normally closed) in this estop line to allow the operator to jog the machine while holding the switch to recover from a warning error.

LED flashing errors (Older Viper A&B series)

- Slow flash - Motor is out of position range (motor power still enabled)
- Medium flash - Warn current reached (motor power still enabled)
- Fast flash - Current trip reached and Output power has been disabled
- Very fast - Encoder trip (Exceeded T setting)

Adjusting Balance or Motor Offset

If the motor has a constant load in one direction such as lifting a load then there may be more of an error in one direction than the other.

The balance command lets you preset a PWM value other than Zero as its neutral, so even with zero error the motor will be applying torque in that direction.

To adjust this setting , disconnect the encoder and step inputs.

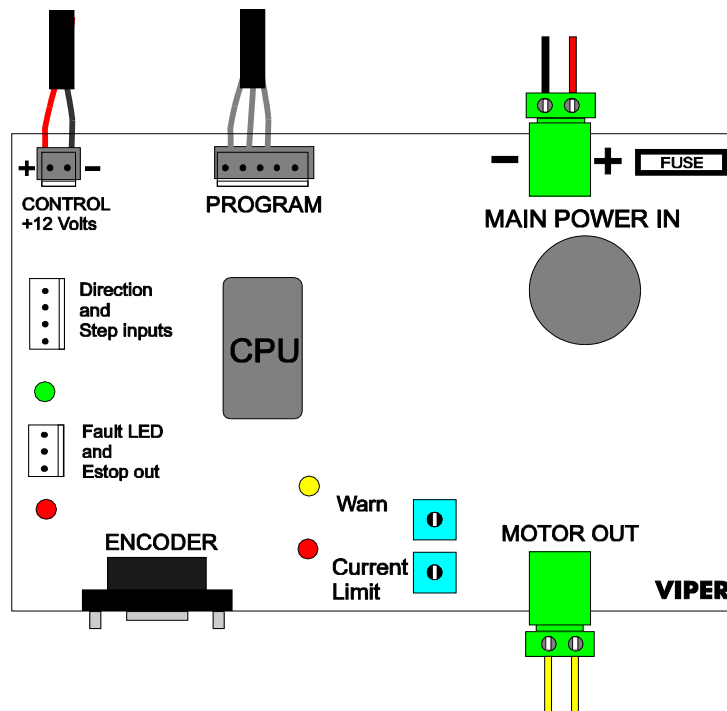

Without the encoder connected and with no step input there will be **no error** . This will make the drive output a zero PWM value (50% effective at the motor).

Change the 'b' command until the load is neutralized and the motor stops turning under load. Values of up to + - 100 are allowed, but shouldn't be exceeded since the motor is always under load and may overheat. Use the 's' command to save the setting

A mechanical counter-balance to the machine should be added if the offset is high to prevent motor heating.

Friction Compensation

On systems where there is a lot of friction (or stiction) the motor may not start to turn at all until it hits certain level of power. So the motor may not start the load until the PWM is at least 10.

The 'h' command allows you to set the lowest PWM value (which is normally zero). To tune this command, connect the drive with the encoder disconnected.

You will need to have a Step/dir source that can output 1 pulse at a time to create an error which causes the PWM to gradually increase.

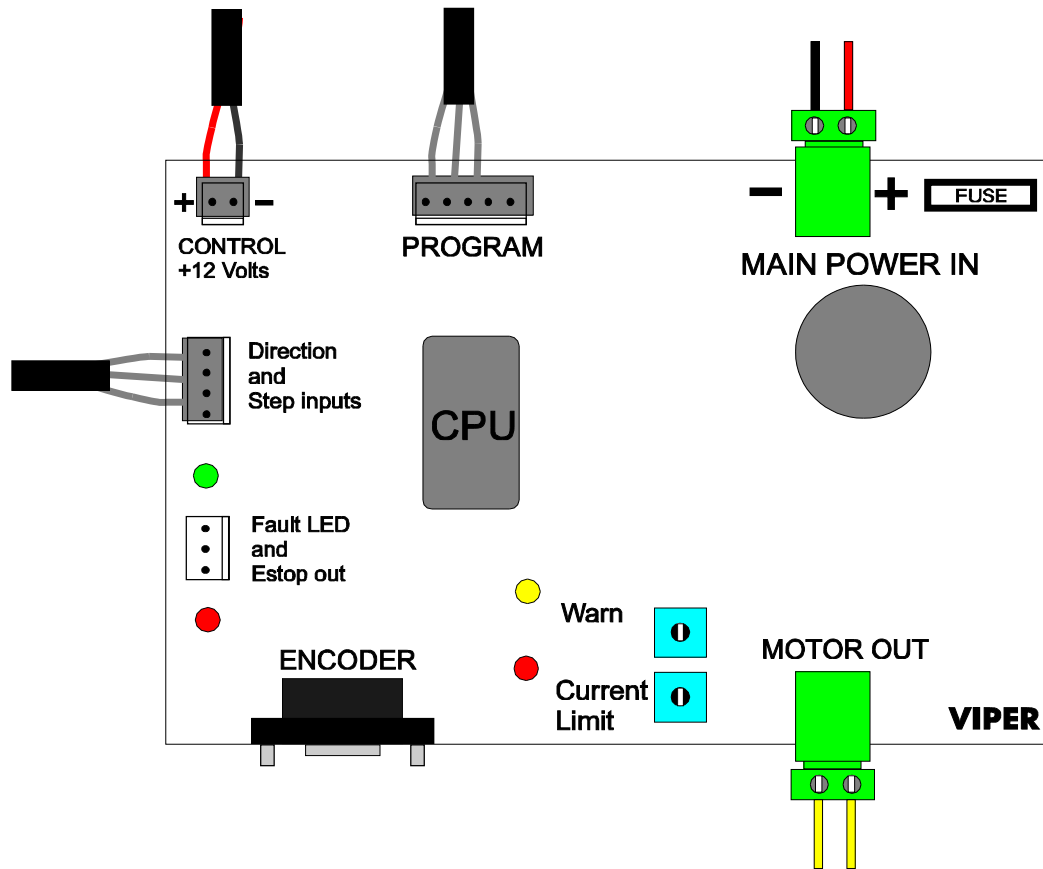

First, lower the 'p' setting to 50 and set 'i' to zero and 'd' to zero . Set the 'h' command to zero also.

Slowly apply step pulses one at a time and the motor should start to turn.

Use the ? Command to see what the drives output PWM value is currently at.

Apply step pulses in the opposite direction and until the motor just stops turning. Read the drives PWM value and write it down. This is the value the h command needs to overcome the friction in the system. Enter it and use the 's' command to save the setting.

Viper command set

Command	Description	Example
Data entry		
p nnnn	Enter Proportional term	p800<cr>
i nnnn	Enter Integral term	I6<cr>
d nnnn	Enter Derivative term	d1400<cr>
j nn	Enter step size (jump)	j3<cr>
l nn	Enter Loop term	l4<cr>
n nn	Enter number of bank	b3<cr>
r nnnn	Enter error range limit	r64<cr>
c nn	Enter pwm Clip limit (100-450)	c350<cr>
h nn	Enter hysteresis (friction) compensation	h5<cr>
b nn	Enter Balance control (motor offset)	b-15<cr>
f nnnn	Enter Feed_Forward term	f250<cr>
t nnnn	Enter encoder Trip limit	t2200<cr>
a nn	Enter current parameter	a127<cr>
Read data		
1	Read settings group 1	1<cr> Returns N, P, I, D, L, data
2	Read settings group 2	2<cr> Returns F, T, (PWM) data
3	Read settings group 3	?<cr> Returns A,Real_current,pot
e	Get servo error in Hex	e<cr> -00A1
v	Get software version	v<cr> V2
m	Get motor encoder and step position	m<cr> m00F0 s00F1 (hex result)
Other		
o	Disable power to motor	o<cr>
x	Enable motor power	x<cr>
z	Set defaults and save to EEprom	z<cr>
s	Save settings to EEprom	s<cr>

Notes <cr> = enter. Only change Bank# if you are entering data for banks other than the bank selected by the jumper (for saving).

Run the windows **Hyper Terminal** program from the Accessories group. Create a New session using Comm1, 9600 baud, 8,1,N. In the advanced tab, set Flowcontrol to 'None'
If Hyper-term isn't on your system then it can be installed from your windows cd rom or downloaded from the internet.

All commands are entered in lowercase and followed by a 'carriage return' <cr>.

Example screen shot of Hyperterm.

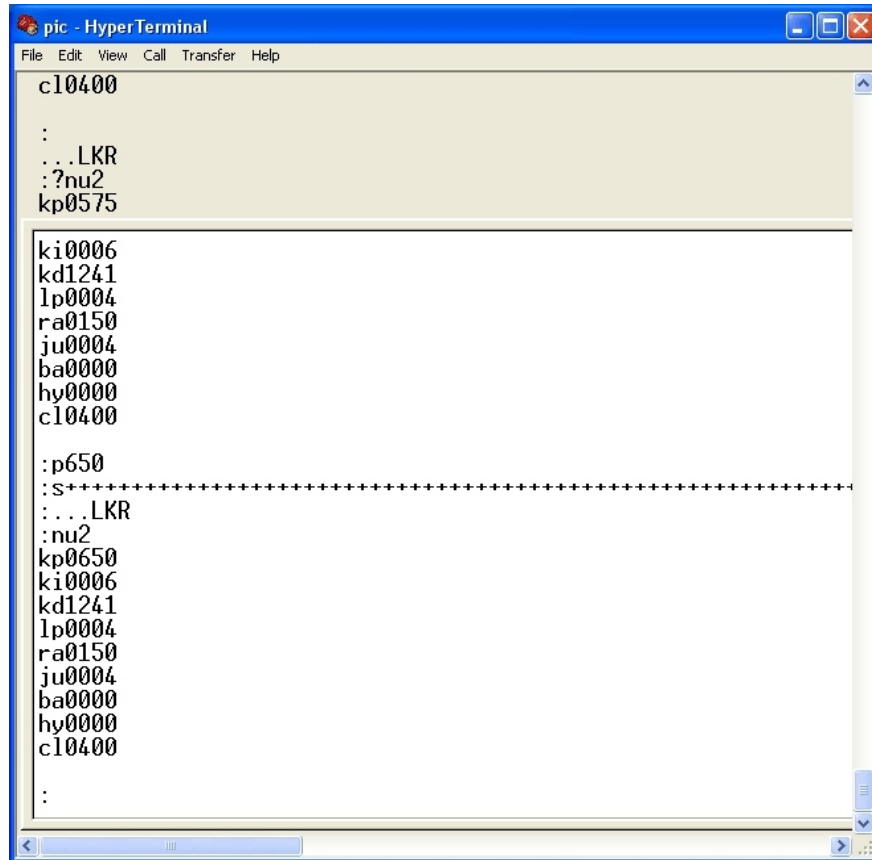

- The ? Command shows the current settings. The Kp is 575
- A new Kp of 600 is programmed using the command p650
- The bank is saved.
- Power is disconnected and the drive reset which shows LK R
- The ? Command shows the Kp was changed to 650 and stored in EEprom.

Selecting Jumpers

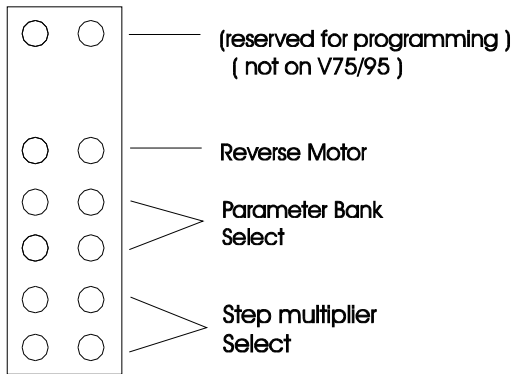

Jumpers are used to select Parameter Bank, Step multiplier and Motor direction.

Jumpers are read on powerup
Reset power to read moved jumpers

Reverse motor jumper allows changing motor to run CCW or CW

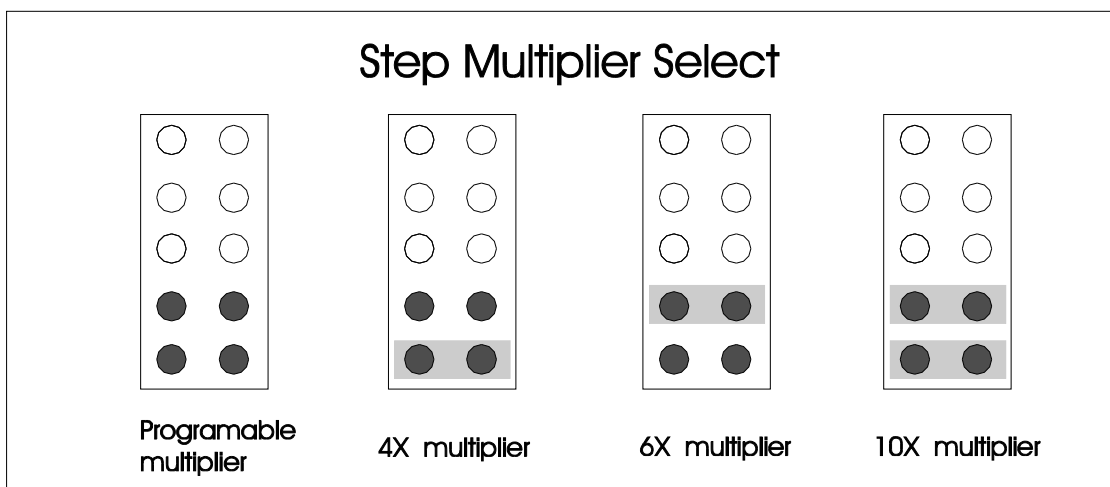
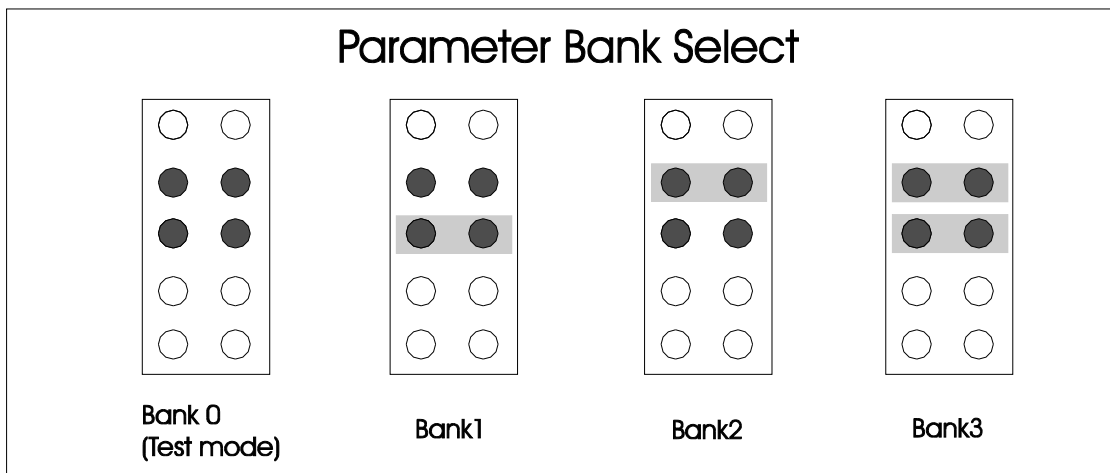

Component Data

Parts supply

(Available from Digikey www.Digikey.com 1-800-344-4539)

Fuse 5, 7.5, 10, 15 or 20 amp automotive type. Select the fuse amperage to protect motor winding or machine from damage incase of drive failure.

Power Mosfets for Viper 100 / 200 IRFB 4232 PBF 56 amp 250volt mosfet
Mosfet driver chips IR 2104 8 pin dip

Connectors

Output and motor power (Viper 100s)

Digikey Part #	Description
277-1011-ND	Pheonix 2 pin plug green power 10 amp

Output and motor power (Viper 200)

277-1463-ND	Pheonix 2 pin plug green power 20 amp
-------------	---------------------------------------

Small connectors

Digikey Part #	Description
WM2200-ND	tiny Crimp term .1" for block
WM2000-ND	Housing 2 Pin .1" (for 15 volt power)
WM2001-ND	Housing 3 Pin .1" (for fault output)
WM2002-ND	Housing 4 Pin .1" (for step/ direction)
WM2003-ND	Housing 5 Pin .1" (for RS232)

A Crimping tool for .1" block connectors is highly recommended

For a professional job, use a crimp tool such as this one from
<http://www.action-electronics.com/molex.htm>

PHT-98-601 NON-INSULATED OPEN BARREL AND D-SUB V35 CONN



